

Signature Series

Maximum Resilience Broadcast Audio



Signature ADA 2S12MGT

Transformer Balanced 1 Stereo Input 12 Mono Output Distribution Amplifier With Gain Controls



ADA 2S12MGT Front



ADA 2S12MGT Rear

FEATURES

1 x stereo input or 1 x mono input to 12 x mono outputs

Transformer balanced audio outputs

Each input & output has individual gain controls

Input & Outputs can accept balanced and unbalanced connections

The Signature ADA2S12MGT is a broadcast specification 12 way mono analogue distribution amplifier, designed to distribute stereo audio channels to multiple mono destinations.

The ADA 2S12MGT has 1 x stereo input that is distributed to 12 x mono outputs. The two audio inputs (1 stereo circuit) each have their own input gain preset controls. These allow an engineer to set the inputs up to work with levels that suit you, such as mono out = A+B-3 or A+B-6 or 0dB in = 0dB out, or even adjust the inputs for accepting unbalanced domestic levels.

Each of the 12 outputs also have preset gain controls, this allows different outputs to be connected and lined up with different systems. Audio inputs and outputs are transformer balanced on XLRs and can accommodate unbalanced connections if required.

The input & output gains are on front panel multi-turn potentiometers (recessed to prevent accidental operation). They provide a wide gain range to cope with the different gain level requirements of broadcast or domestic level equipment.

All outputs are protected, so a short circuit on one will not affect any of the others. Audio transformers help to make this unit an ultra reliable broadcast distribution amplifier suitable for the heart of your operation.

Power is provided by an internal switch mode power supply, with a wide input range. There is also an input for external 12V DC power. The 12V DC input can be connected to the optional Signature PS1 external DC Master Power Station, for situations where a redundant power supply is desirable.

A bright front panel LED indicates that the unit is operational.



Glensound
Keeps Working



Signature ADA 2S12MGT

Transformer Balanced 1 Stereo Input 12 Mono Output Distribution Amplifier With Gain Controls

EXAMPLE APPLICATION

Radio Station CTA

Six Output Stereo Distribution

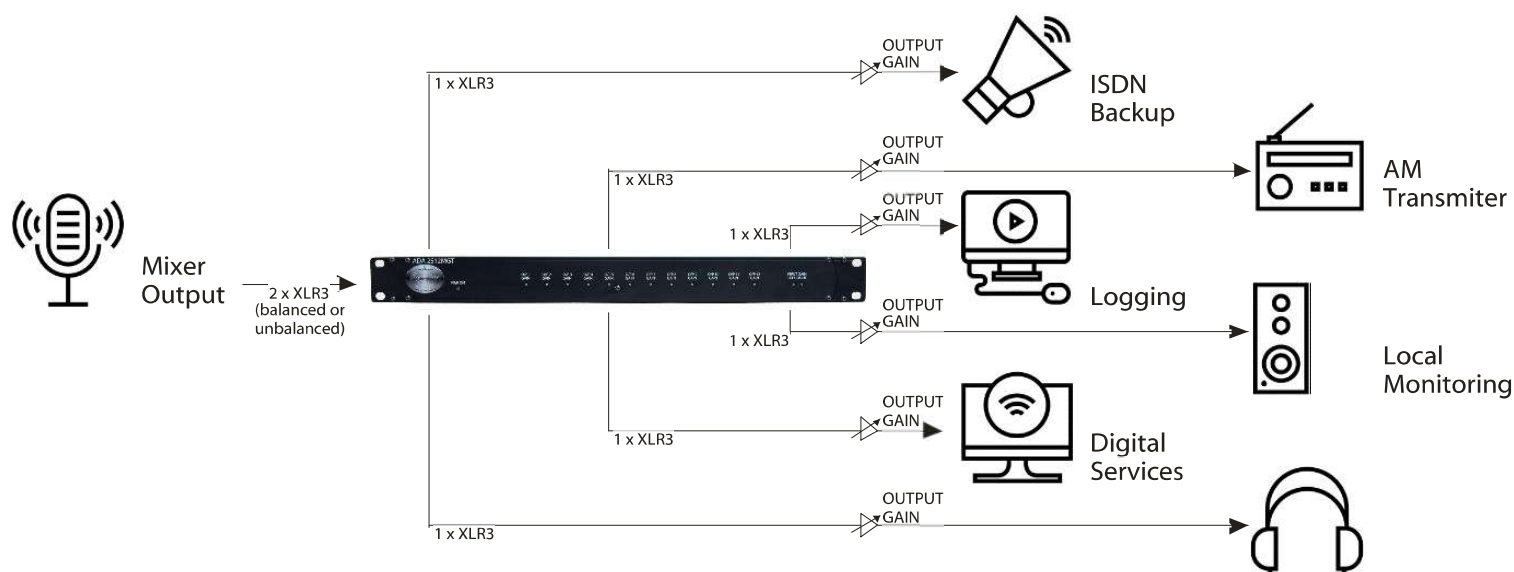

The main stereo programme audio from a radio station needs to be distributed across multiple mono platforms. The output from the desk or automation system no longer just heads off to the transmitter. The audio must be distributed across all of the relevant services that require a connection of the original programme audio.

In this example, the Signature ADA1S12MGT provides 6 mono outputs of the main programme audio. One output connects to the AM transmitter as an alternative to the main FM broadcast feed. As multiple monitoring headphones are required in the studio, another output connects to a separate headphone distribution amplifier. This station also broadcasts online, so another output connects to a PC to become the internet broadcast stream. Local monitoring is required, so one feed goes to the local monitoring system.

The transmitter B chain is on ISDN, so one output goes to the mono ISDN backup codec. And the final output connects to another PC that manages all of the stations logging requirements.

All of these distributed sources may require different levels. With the Signature ADA1S12MGT, each distributed output can have a different gain level set so that it matches the incoming level requirements of each source. For example, the feed that goes to the AM transmitter link will be connected to professional equipment expecting normal line up levels. However, the station logging may be on a domestic grade PC and require a much lower input level to be sent to it. Using the ADA1S12MGT, a separate gain level can be set for each output.



Signature Series

Maximum Resilience Broadcast Audio



Signature ADA 2S12MGT

Transformer Balanced 1 Stereo Input 12 Mono Output
Distribution Amplifier With Gain Controls

EXAMPLE APPLICATION

Commentary Feed In IBC

Twelve Output Mono Distribution

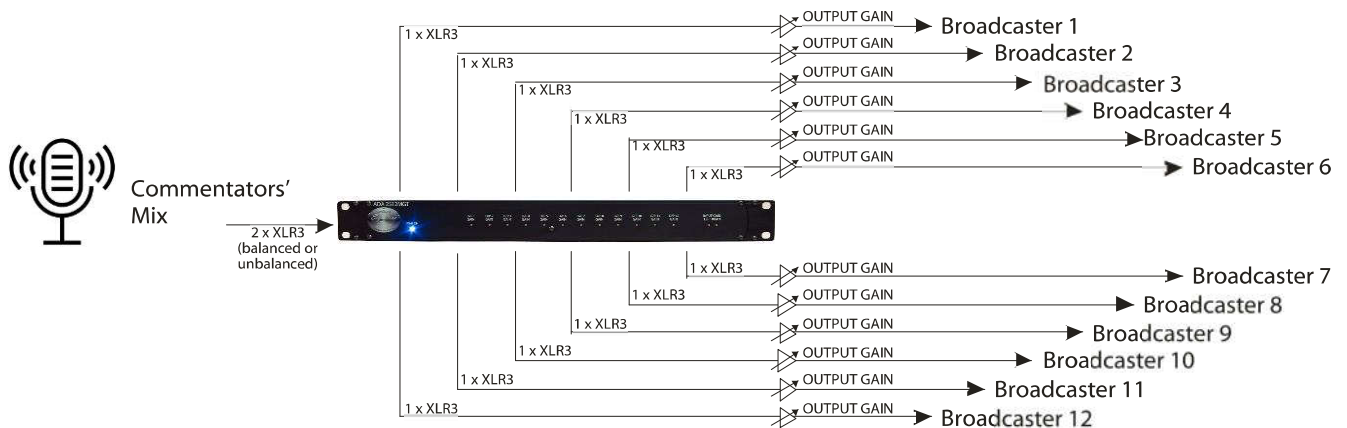

A stereo feed is connected to the Signature ADA2S12MGT. This could be the master programme mix output from a host commentary system at a sports stadium. This needs to be distributed to all the relevant broadcasters who want to take the host commentary audio.

Twelve outputs from the ADA2S12MGT are available, which all contain the original audio, and are available to distribute to all of the relevant 12 broadcasters. As the required levels may be different for each broadcaster the gain can be adjusted independently for each output.

SPECIFICATION

AUDIO

Frequency Response

<+/-1dB 20Hz to 24kHz

Gain Range

+10dB to -15dB on each output
+6dB to -21dB on each input

Maximum Levels

>+28dB Input
>+24dBu Output

Input Impedance

>30k Ω

Output Impedance

=<50 Ω

Distortion Ref +8dBu output

THD+N 0.003% @ 10kHz
THD+N 0.005% @ 1kHz
THD+N 0.06% @ 100Hz

Noise

-81dBu @ line up unweighted
RMS (22Hz to 22kHz)

Common Mode Rejection @ Line Up

> -67dB @ 20kHz
>-112dB @ 1kHz
>-100dB @ 50Hz

Input & Output Type

Transformer balanced (can be wired
Unbalanced) on Neutrik 3 pin XLR socket

POWER

Mains Input

Filtered IEC, 100 to 240VAC
47 - 63Hz

AC Consumption

1.5 Watts @ 230VAC

DC Input

4 Pin Neutrik XLR plug +/- 12V
+12V = 30mA -12V = 24mA

Internal Mains Fuse

20mm 500mA Anti Surge

PHYSICAL

Size

445 x 123 x 44mm (LxDxH) no rack ears
482mm 19" (1RU) with rack ears

Weight

1.75kg

Mechanics

All aluminium construction, anodized and
laser etched

Shipping Carton

Rugged export quality cardboard carton
610 x 420 x 130mm LxDxH

Shipping Weight

3.5kg

E & OE

Signature Series

Maximum Resilience Broadcast Audio



Signature ADA 2S12MGT

Transformer Balanced 1 Stereo Input 12 Mono Output Distribution Amplifier With Gain Controls

AUDIO BLOCK DIAGRAM

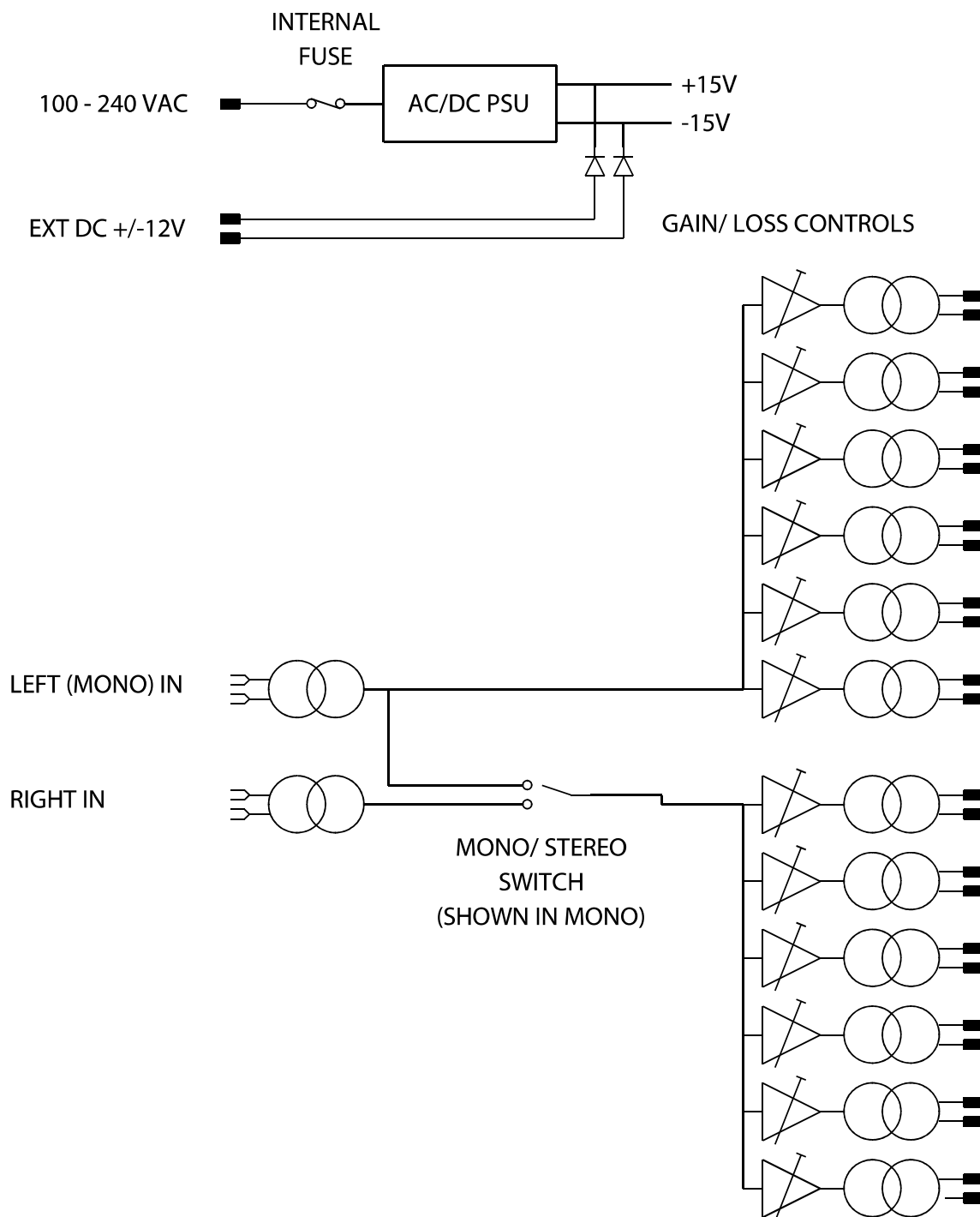

Signature Series

Maximum Resilience Broadcast Audio



Signature Series Standard Features

STANDARD FEATURES

19" Rack Mount Ears



A Signature unit can rack mount in a 1U 19" rack, regardless of the size of the unit. Rack ears are included as standard with every unit.

Front Or Rear Mounting



A Signature unit can be rack mounted via the front panel or if it is more convenient, via the rear panel by simply swapping the rack ears over.

Side Wings For Flat Surface Fixing



A Signature unit has side wings with mounting holes at the top and bottom, allowing flush fixing from above **OR** underneath.

Neutral Colour Scheme To Complement Equipment Areas



Rack Screws Included



Modern Design



Internal Switch Mode AC Power Supply



A Signature unit has an internal switch mode AC power supply, allowing worldwide power connections from 100-240v via an IEC socket.

12V DC Power Connection



All Signature units (except PS1) have a 4 pin XLR $\pm 12V$ DC socket for connection to the PS1 Power Station. This can act as the primary or backup power source.

Quick Find Manual



A Signature unit has a QR code attached. This can be scanned to simply and quickly locate the manual and technical information.

CONTACT

Glensound
6 Brooks Place, Maidstone
Kent, UK, ME14 1HE
Tel: +44 (0)1622 753 662
Web: www.glensound.com
Email: sales@glensound.com

Glensound
Keeps Working